

LOGWOOD



LOGWOOD

white

2 formati - 7 colori - 2 superfici
2 formats - 7 colors - 2 surfaces

grey

brown

cream

16,4x99,8 Out

beige

nut

16,4x99,8

taupe

24,8x99,8





LOGWOOD



white

Semplicità, eleganza, la naturalezza

**Simplicity, elegance,
del legno...**

naturalness Wood ...

white





LOGWOOD



cream



**Vivere la natura attraverso
Experience nature through
le sfumature del legno...
wood shades ...**







cream



cream









LOGWOOD

beige

L'originalità e il fascino

The originality and charm

di una linea autentica...

a line of authentic ...

beige



Beige 16,4x99,8 - 6,6"x39,9"
Beige 24,8x99,8 - 9,9"x39,9"



LOGWOOD



taupe

Ottima abbinabilità e incomparabile

Excellent abbinabilità incomparabile

bellezza estetica...

beauty and aesthetic ...







taupe



Taupe 16,4x99,8 - 6,6"x39,9"
Taupe 24,8x99,8 - 9,9"x39,9"



The background of the slide is a collage of wood textures. The top-left corner features a vertical strip of dark, rich brown wood with a fine, straight grain. The middle section is dominated by a large, horizontal plank of dark brown wood with a prominent, wavy grain pattern and several knots. The bottom-left corner shows another vertical strip of dark brown wood with a similar fine grain. The right side of the slide is a solid, light beige color, providing a clean background for the text.

LOGWOOD

nut

**Arredare con gusto e stile
To furnish with taste and style
attraverso la bellezza del legno
through the beauty of the wood**

nut





LOGWOOD



brown

Ampia gamma di tonalità per
Wide range of shades to suit
soddisfare ogni esigenza...
every need...

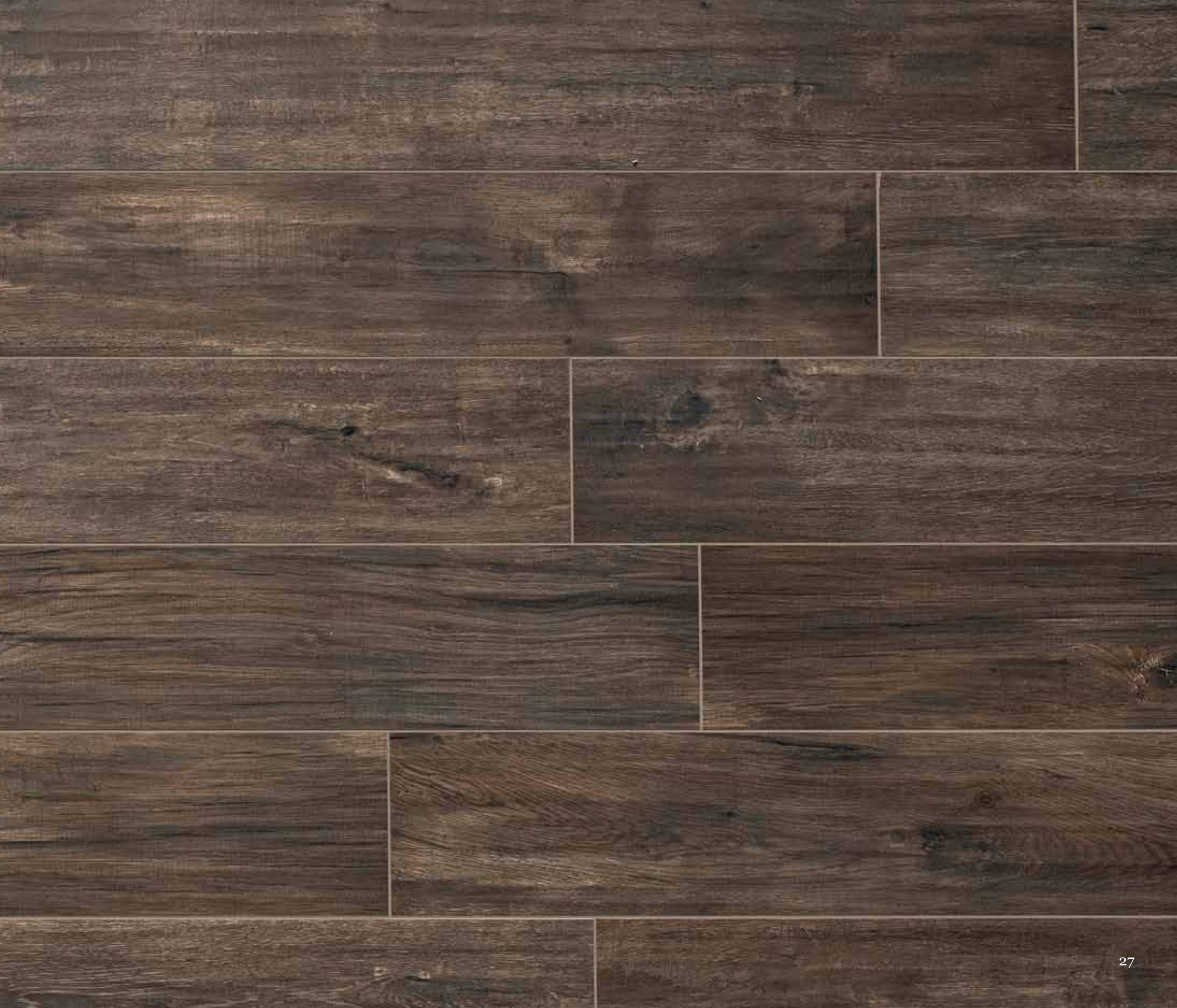



brown



LOGWOOD



grey

**un materiale che racchiude
A material that holds**

**secoli di storia...
centuries of history ...**



grey





LOGWOOD

24,8x99,8 - 16,4x99,8
9,9"x39,9" - 6,6"x39,9"

White



DLOM10 LOGWOOD WHITE MIX 32,6x32,6 12,8"x12,8" 534/MQ



DLO1610 LOGWOOD WHITE 16,4x99,8 6,6"x39,9"

611/MQ



DLO2510 LOGWOOD WHITE 24,8x99,8 9,9"x39,9"

606/MQ



DLOB10 LOGWOOD WHITE BATTISCOPIA 8x99,8 3 1/8"x39,9"

527/PZ

Cream



DLOM20 LOGWOOD CREAM MIX 32,6x32,6 12,8"x12,8" 534/MQ



DLO1620 LOGWOOD CREAM 16,4x99,8 6,6"x39,9"

611/MQ



DLO2520 LOGWOOD CREAM 24,8x99,8 9,9"x39,9"

606/MQ



DLOB20 LOGWOOD CREAM BATTISCOPIA 8x99,8 3 1/8"x39,9"

527/PZ

LOGWOOD

24,8x99,8 - 16,4x99,8
9,9"x39,9" - 6,6"x39,9"

Beige



DLOM80 LOGWOOD BEIGE MIX 32,6x32,6 12,8"x12,8" 534/MQ



DLO1680 LOGWOOD BEIGE 16,4x99,8 6,6"x39,9"

611/MQ



DLO2580 LOGWOOD BEIGE 24,8x99,8 9,9"x39,9"

606/MQ



DLOB80 LOGWOOD BEIGE BATTISCOPA 8x99,8 3 1/8"x39,9"

527/PZ

Grey



DLOM40 LOGWOOD GREY MIX 32,6x32,6 12,8"x12,8" 534/MQ



DLO1640 LOGWOOD GREY 16,4x99,8 6,6"x39,9"

611/MQ



DLO2540 LOGWOOD GREY 24,8x99,8 9,9"x39,9"

606/MQ



DLOB40 LOGWOOD GREY BATTISCOPIA 8x99,8 3 1/8"x39,9"

527/PZ

LOGWOOD

24,8x99,8 - 16,4x99,8
9,9"x39,9" - 6,6"x39,9"

Brown



DLOM70 LOGWOOD BROWN MIX 32,6x32,6 12,8"x12,8" 534/MQ



DLO1670 LOGWOOD BROWN 16,4x99,8 6,6"x39,9"

611/MQ



DLO2570 LOGWOOD BROWN 24,8x99,8 9,9"x39,9"

606/MQ



DLOB70 LOGWOOD BROWN BATTISCOPIA 8x99,8 3 1/8"x39,9"

527/PZ

Taupe



DLOM60 LOGWOOD TAUPE MIX 32,6x32,6 12,8"x12,8" 534/MQ



DLO1660 LOGWOOD TAUPE 16,4x99,8 6,6"x39,9"

611/MQ



DLO2560 LOGWOOD TAUPE 24,8x99,8 9,9"x39,9"

606/MQ



DLOB60 LOGWOOD TAUPE BATTISCOPA 8x99,8 3 1/8"x39,9"

527/PZ

LOGWOOD

24,8x99,8 - 16,4x99,8
9,9"x39,9" - 6,6"x39,9"

Nut



DLOM50 LOGWOOD NUT MIX 32,6x32,6 12,8"x12,8" **534/MQ**



DLO1650 LOGWOOD NUT 16,4x99,8 6,6"x39,9"

611/MQ



DLO2550 LOGWOOD NUT 24,8x99,8 9,9"x39,9"

606/MQ



DLOB50 LOGWOOD NUT BATTISCOPA 8x99,8 3 1/8"x39,9"

527/PZ

Pezzi speciali - Special Pieces

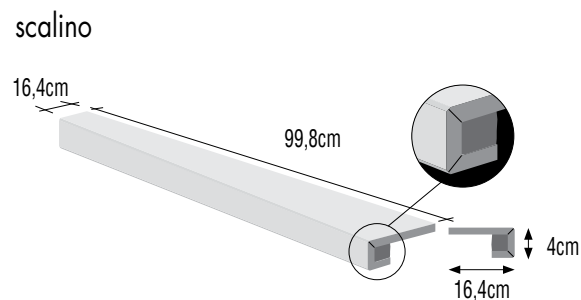

DL010S	LOGWOOD BIANCO SCALINO C. RETTA	16,4X99,8	9,9"x39,9"
DL020S	LOGWOOD CREAM SCALINO C. RETTA	16,4X99,8	9,9"x39,9"
DL080S	LOGWOOD BEIGE SCALINO C. RETTA	16,4X99,8	9,9"x39,9"
DL040S	LOGWOOD GREY SCALINO C. RETTA	16,4X99,8	9,9"x39,9"
DL070S	LOGWOOD BROWN SCALINO C. RETTA	16,4X99,8	9,9"x39,9"
DL060S	LOGWOOD TAUPE SCALINO C. RETTA	16,4X99,8	9,9"x39,9"
DL050S	LOGWOOD NUT SCALINO C. RETTA	16,4X99,8	9,9"x39,9"

785/PZ

Nelle scatole la disposizione delle piastrelle è casuale ed alcune potrebbero ripetersi: si consiglia quindi di miscelare i pezzi prima delle pose.
 In the boxes the disposition of the floor tiles is accidental and some could be repeated: it is advised therefore of miscelare the pieces before placed.
 Dans les boîtes la disposition des carreaux est fortuite et certaines pourraient se répéter : on conseille donc de mélanger les pièces avant posa.
 Boxen in der Anordnung der Fliesen ist zufällig und einige vielleicht wiederholt werden: Es wird vorgeschlagen, um die Stücke platziert, bevor mischen.



grey out



grey out





LOGWOOD OUT

16,4x99,8
6,6"x39,9"

White



DLO16100 LOGWOOD WHITE OUT 16,4x99,8 6,6"x39,9"

613/MQ

Cream



DLO16200 LOGWOOD CREAM OUT 16,4x99,8 6,6"x39,9"

613/MQ

Beige



DLO16800 LOGWOOD BEIGE OUT 16,4x99,8 6,6"x39,9"

613/MQ

Grey



DLO16400 LOGWOOD GREY OUT 16,4x99,8 6,6"x39,9"

613/MQ

Brown



DLO16700 LOGWOOD BROWN OUT 16,4x99,8 6,6"x39,9"

613/MQ

Taupe



DLO16600 LOGWOOD TAUPE OUT 16,4x99,8 6,6"x39,9"

613/MQ

Nut



DLO16500 LOGWOOD NUT OUT 16,4x99,8 6,6"x39,9"

613/MQ

Pezzi speciali - Special Pieces

scalino

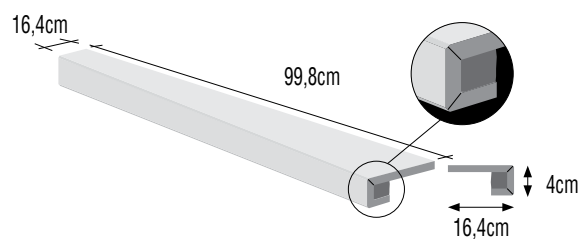

DL010OS	LOGWOOD BIANCO OUT SCALINO C. RETTA	16,4X99,8	9,9"x39,9"
DL020OS	LOGWOOD CREAM OUT SCALINO C. RETTA	16,4X99,8	9,9"x39,9"
DL080OS	LOGWOOD BEIGE OUT SCALINO C. RETTA	16,4X99,8	9,9"x39,9"
DL040OS	LOGWOOD GREY OUT SCALINO C. RETTA	16,4X99,8	9,9"x39,9"
DL070OS	LOGWOOD BROWN OUT SCALINO C. RETTA	16,4X99,8	9,9"x39,9"
DL060OS	LOGWOOD TAUPE OUT SCALINO C. RETTA	16,4X99,8	9,9"x39,9"
DL050OS	LOGWOOD NUT OUT SCALINO C. RETTA	16,4X99,8	9,9"x39,9"

785/PZ

Nelle scatole la disposizione delle piastrelle è casuale ed alcune potrebbero ripetersi: si consiglia quindi di miscelare i pezzi prima delle pose.
 In the boxes the disposition of the floor tiles is accidental and some could be repeated: it is advised therefore of miscelare the pieces before placed.
 Dans les boîtes la disposition des carreaux est fortuite et certaines pourraient se répéter : on conseille donc de mélanger les pièces avant posa.
 Boxen in der Anordnung der Fliesen ist zufällig und einige vielleicht wiederholt werden: Es wird vorgeschlagen, um die Stücke platziert, bevor mischen.

Dati tecnici secondo norme: Technical data conform to: Caractéristiques techniques d'après normes: Technische Daten nach den Normen:			LOGWOOD	LOGWOOD OUT
	Caratteristiche tecniche Technical data Caractéristiques techniques Technische Daten	Norme Normes Normes Norm	Valori Value Valeur Wert	Valori Value Valeur Wert
	Resistenza all'abrasione Abrasion resistance Resistance à l'abrasion Abrasionswiderstandigkeit	ISO 10545-7	PEI V	PEI V
	Assorbimento d'acqua Water absorption Absorption d'eau Wasseraufnahme	ISO 10545-3	≤ 0,5%	≤ 0,5%
	Resistenza alla flessione Breaking modulus Résistance à la flexion Biegefestigkeit	ISO 10545-4	40±55 N/mm2	40±55 N/mm2
	Durezza Mohs Mohs hardness Dureté Mohs Haerte Mohs	EN101	8	7
	Resistenza all'attacco acido e basico Glaze resistance to acid and alkaline attack Resistance aux acides et aux bases Saeure-und laugenfestigkeit	ISO 10545-13	Resiste Resists Resiste Bestanding	Resiste Resists Resiste Bestanding
	Resistenza alle macchie Stain resistance Résistance aux taches Fleckenfestigkeit	ISO 10545-14	Totale Complete Totale Absolut	Totale Complete Totale Absolut
	Resistenza al gelo Resistance to frost Résistance au gel Frostbeständigkeit	ISO 10545-12	Non gelive Frost proof Ingélf Frostsicher	Non gelive Frost proof Ingélf Frostsicher
	Scivolosità Slipperiness Degré de glissement Rutschhemmung	DIN 51130	R10	R11
ASTM	Scivolosità Slipperiness Degré de glissement Rutschhemmung	ASTM C1028	>0,60	>0,60
	Resistenza allo scivolamento Slip resistance Résistance au glissement Rutschhemmung	DIN 51097	B	C
	Scivolamento B.C.R.A. Slipperiness B.C.R.A. Degré de glissement B.C.R.A. Rutschhemmung B.C.R.A.	TORTUS	>0,40	>0,40

I valori indicati nella tabella si riferiscono alle prove eseguite sul colore CREAM.

The values in the table refer to the tests performed on color CREAM.

Les valeurs indiquées dans le tableau se réfèrent aux essais exécutés sur le couleur CREAM.

Die in der Tabelle angegebenen Werte beziehen sich auf die Tests die auf dem Farbe CREAM ausgeführt wurden.

Los valores indicados en la tabla se refieren a las pruebas efectuadas con el color CREAM.

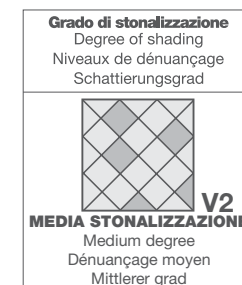

CONSIGLI PER LA POSA

POSA A CORRERE - La posa a "correre" necessita una maggiore premura nelle fasi di livellaggio e accostamento dei singoli pezzi, per poter attenuare eventuali differenze di planarità.

Sebbene inevitabili queste piccole differenze non compromettono un buon risultato finale: dunque è consigliato sfalsare i singoli pezzi di 15-20 cm massimo.

IMPORTANTE - La posa sfalsata al 50% non è consigliata. Trattandosi di materiali ceramici si suggeriscono le seguenti pose:

FIXING ADVICE

PARALLEL FIXING - To minimize differences in the flatness of the tiles, "parallel" fixing requires greater attention when the individual tiles are positioned and levelled.

Although these small differences are inevitable, they will not spoil a good final result: the individual tiles should thus be staggered 15-20 cm at most.

IMPORTANT - Please note that fixing in a 50% staggered configuration is not recommended. We suggest the following fixing configurations for these ceramic materials:

CONSEILS DE POSE

POSE A FOND PERDU - La pose à "fond perdu" nécessite une très grande attention dans les phases de nivellement et d'assemblage des différentes pièces, de manière à atténuer les différences éventuelles de planéité. Ces petites différences sont inévitables, mais ne compromettent pas un bon résultat final: il faut donc décaler les différentes pièces de 15-20 cm maximum.

IMPORTANT - A pose décalée à 50% n'est pas recommandée. Pour les matériaux céramiques nous conseillons les poses suivantes:

TIPPS ZUR VERLEGUNG

FORTLAUFENDE VERLEGUNG - Die fortlaufende Verlegung (eine Platte nach der anderen) erfordert mehr Sorgfalt beim Ebenen und Anlegen der einzelnen Teile, um eventuelle Ebenheitsunterschiede zu mindern. Obwohl sie unvermeidlich sind, stellen diese kleinen Unterschiede keine Beeinträchtigung des guten Endergebnisses dar:

Es ist deshalb ratsam, die einzelnen Teile um max. 15-20 cm zu versetzen.

WICHTING! - Die um 50% versetzte Verlegung nicht empfohlen ist. Da es sich um Keramikmaterial handelt, kann man die folgenden Verlegungen empfehlen:

SÌ POSA 10%/20%

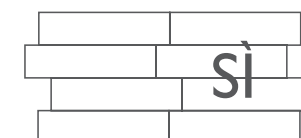

NO POSA 50%

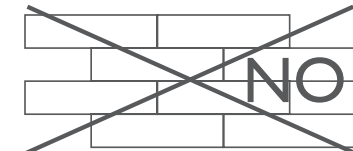

Imballi - Packing - Emballage - Verpackung			PORCELLANATO IMPASTO COLORATO		LOGWOOD		
FORMATO size format	Pz./SCATOLA pieces/box pieces/boîte	Mq./SCATOLA sqm/box mq/boîte	Kg./SCATOLA Kg/box Kg/boîte	SCATOLA/PALLET boxes/pallet boîtes/palette	Mq./PALLET sqm/pallet mq/pallet	Kg./PALLET Kg/pallet Kg/pallet	SPESSORE Thickness Epaisseurs
24,8x99,8 / 9,9"x39,9"	4	1,000	26,00	44	44,00	1.159	10,5 mm
16,4x99,8 / 6,6"x39,9"	4	1,000	26,00	48	48,00	1.263	10,5 mm
16,4x99,8 / 6,6"x39,9" out	4	1,000	26,00	40	40,00	1.055	10,5 mm
32,6x32,6 / 12,8"x12,8" mix	4	-	-	-	-	-	-
8x99,8 / 3 ^{1/8} "x39,9" battiscopa	6	-	-	-	-	-	-
16,4x99,8 / 6,6"x39,9" scalino c. retta	2	-	-	-	-	-	-
16,4x99,8 / 6,6"x39,9" scalino c. retta out	2	-	-	-	-	-	-



